

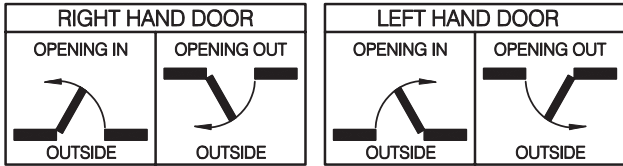

FEL990 Series Electric Mortise Lock Installation Instructions



TO REVERSE LATCH BOLT

1. Remove outer Face Plate
2. Pull & Rotate Latch Bolt 180 degrees clockwise

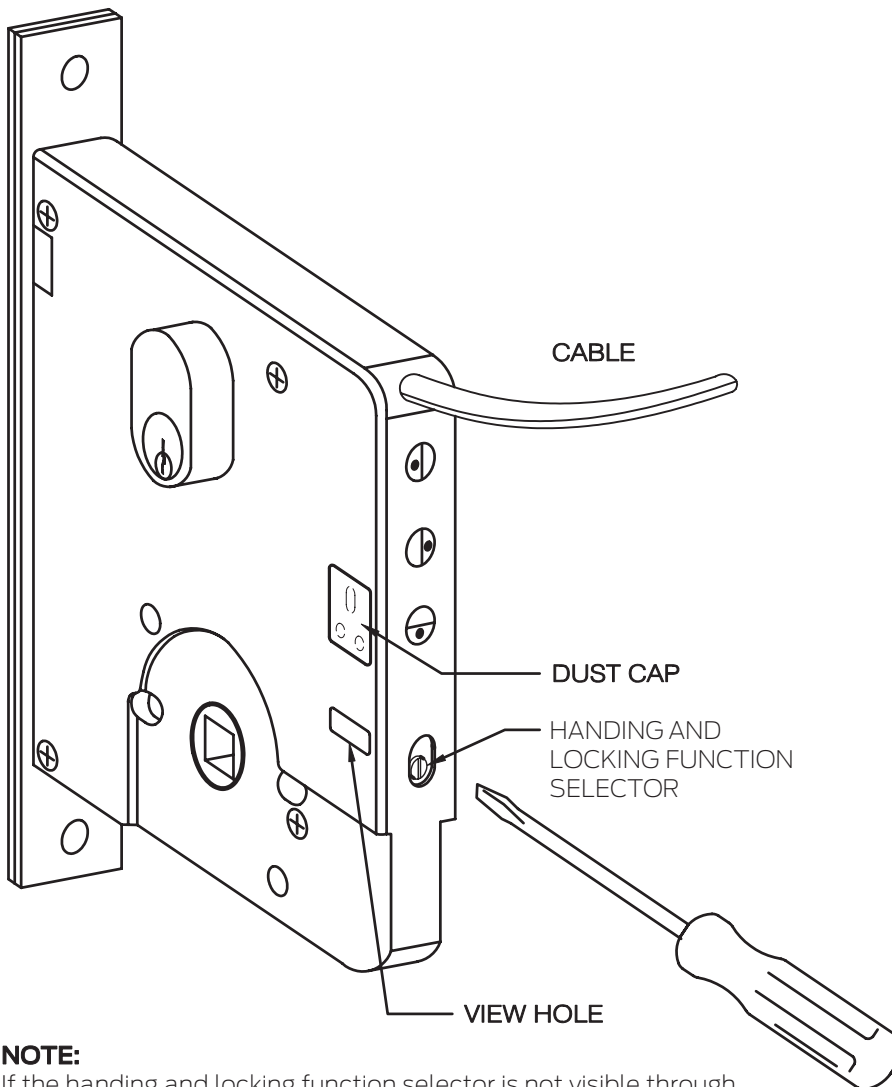
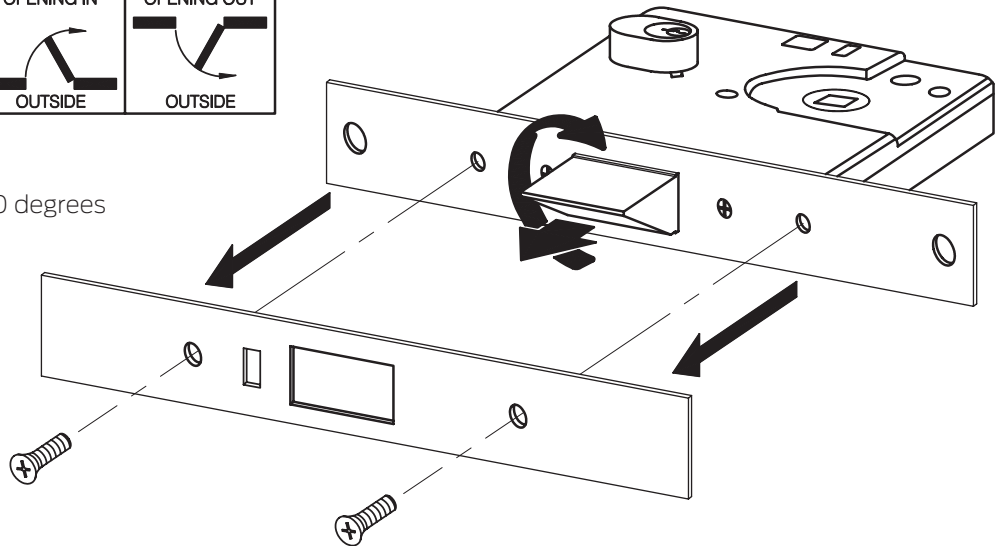

HANDING AND LOCKING FUNCTION SELECTION

For left hand VESTIBULE
Push in and turn clockwise

Set
selector
as shown



For right hand VESTIBULE
Push in and turn anti-clockwise

Set
selector
as shown



To set for COMBINATION
(Both handles lockable)

Set
selector
as shown

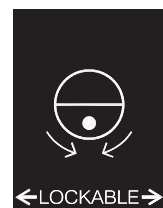

NOTE:

If the handing and locking function selector is not visible through the view hole - the lock is set for Fail Secure (FSE). To make the handing and locking function selector visible, use the holdback clip - see overleaf for Fail Safe (FSA) Fail Secure (FSE) selection.

FAIL SAFE (FSA) / FAIL SECURE (FSE) SELECTION

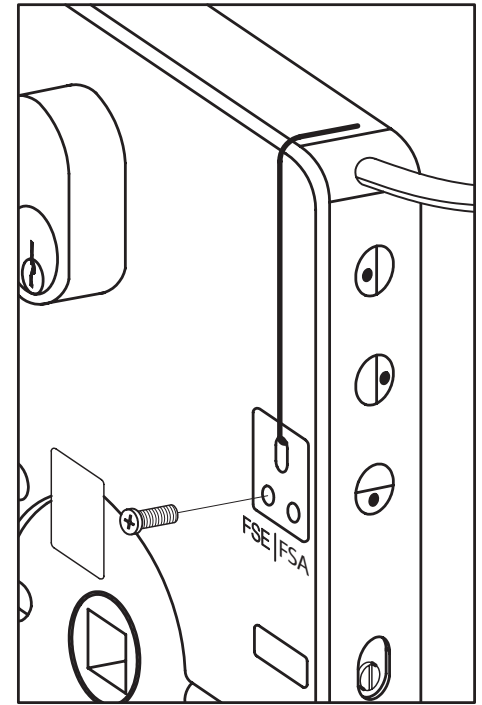
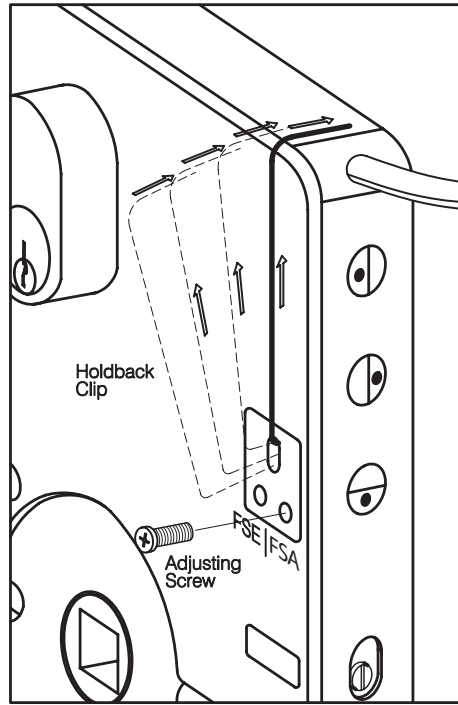
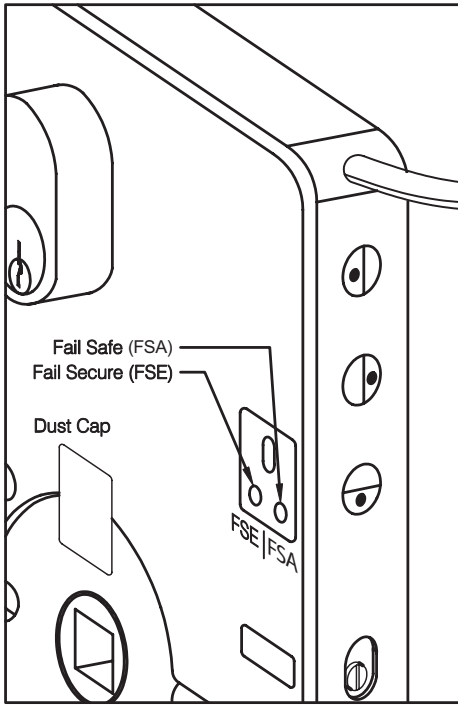

Check that Fail Safe (FSA) / Fail Secure (FSE) function is set to your requirements by first removing the dust cap. The correct FSA / FSE function must be set before setting the vestibule / combination handing function - see detail.

To adjust FSA to FSE, unscrew the adjusting screw and using the FSA / FSE handing holdback clip, position the sharp right-angled wire into the lock cap holdback slot. Gently pull back the FSA | FSE mechanism to the end of the slot and position the opposite (radius) end of the holdback clip over the lock case.

The FSE adjusting screw position is now exposed. Lightly nip the adjusting screw into its new FSE position. Adjust the vestibule / combination handing function to your requirements following the instructions on the back of the lock case - see detail. Unclip the FSA / FSE handing holdback clip and replace the dust cap. FSA / FSE - lock handing function adjustment is now complete.

WARNING - Do not use instruments such as screw drivers to retract the latch bolt through the cylinder hole. Damage to the lock circuitry could occur.

Reverse the sequence of operations to adjust FSE to FSA - lock handing adjustment.

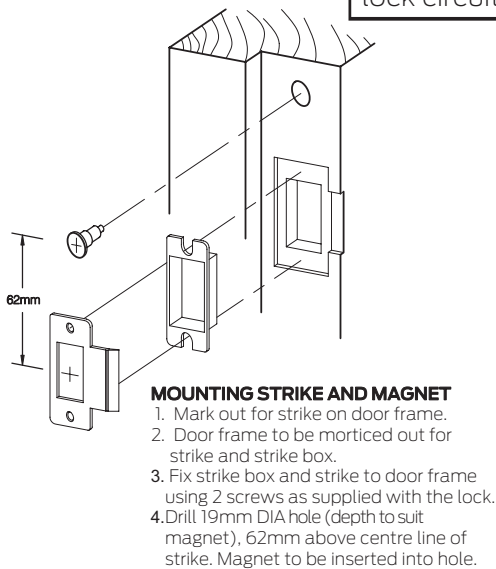

SECURING THE CYLINDER
Use only the Cylinder Retaining Screw supplied, ensuring the Retaining Screw Head is flush with the Inner Forend Face.

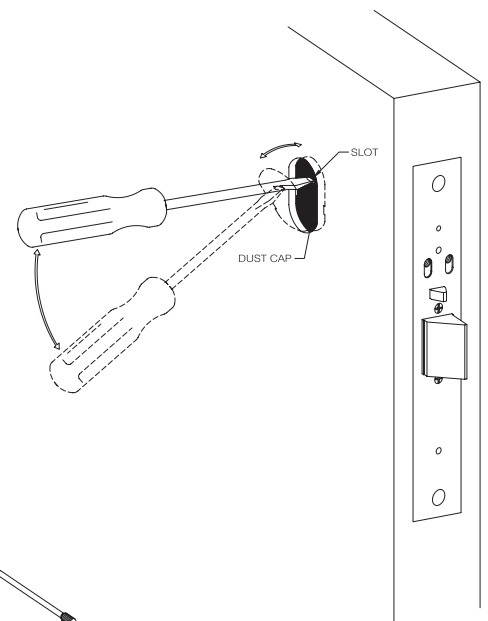

LOCK INSTALLATION
When installing the lock, leave the plastic cylinder dust covers covering the cylinder hole to prevent particles from entering the lock. Where a cylinder is required, extract the dust cover as shown in the illustration.

MORTICE INSTRUCTIONS

1. CUT MORTICE SLOT USING TEMPLATE FOR CORRECT SIZE
2. FIT LOCK INTO MORTICE, SCRIBE AROUND FOREND AND REMOVE WOOD TO ALLOW FLUSH FIT TO DOOR
3. REMOVE LOCK AND USE TEMPLATE TO MARK AND DRILL HOLES TO SUIT LOCK AND FURNITURE BEING USED

- 127mm Backset
- 89mm Backset
- 70mm Backset
- 60mm Backset

IMPORTANT
A MAXIMUM CLEARANCE OF 5mm IS RECOMMENDED BETWEEN LOCK FOREND AND STRIKER PLATE FOR SECURITY REASONS

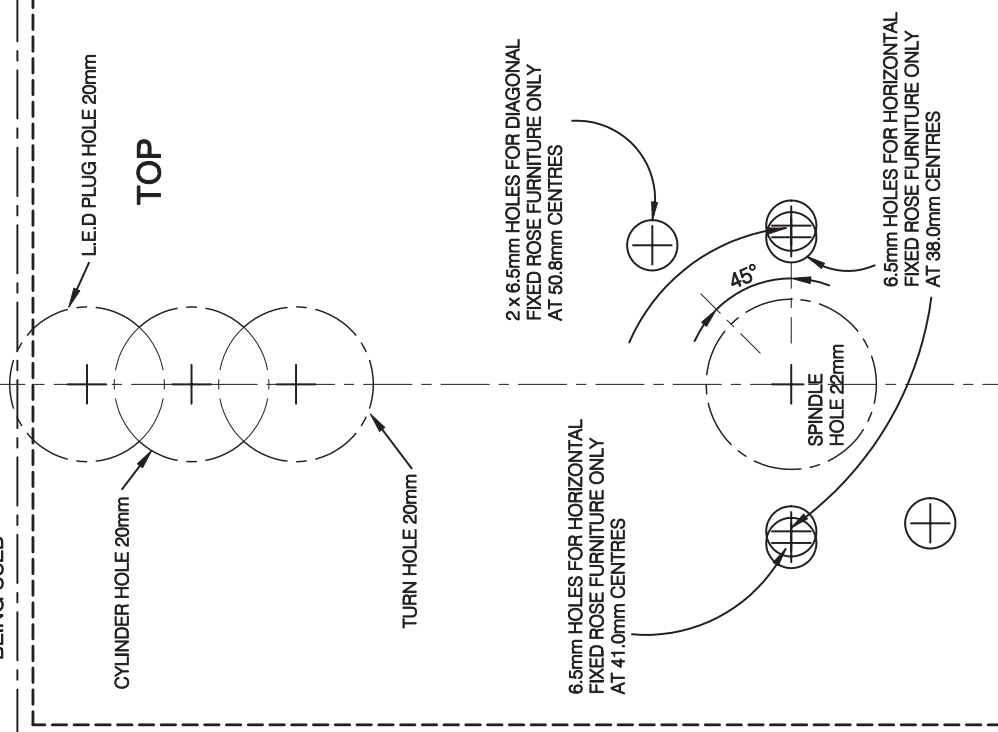

DEPTH OF MORTICE IS 125mm FOR 60mm BACKSET

- 60mm Backset
- 70mm Backset
- 89mm Backset
- 127mm Backset

CHECK CAREFULLY:
DO NOT DRILL HOLES RIGHT THROUGH DOOR. THE FURNITURE MAY NOT COVER ANY HOLES THAT ARE INCORRECTLY DRILLED

DEPTH OF MORTICE IS 125mm FOR 60mm BACKSET

FEL990 SERIES LOCKS ARE DESIGNED FOR USE WITH SPRUNG DOOR FURNITURE. THE USE OF **UNSPRUNG** DOOR FURNITURE IS NOT RECOMMENDED

12 PIN PLUG CONNECTION (3m of cable supplied as standard)

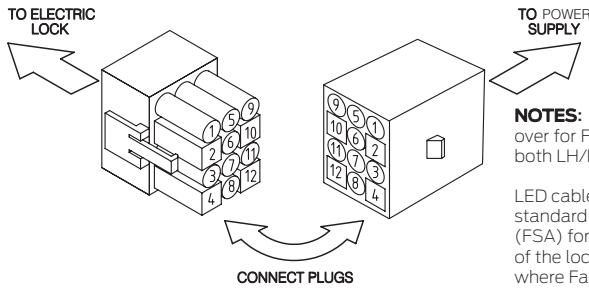

NOTES: Swapping LED wires over for Fail Secure (FSE) for both LH/RH sides of lock.

LED cables are supplied as standard to suit Fail Safe (FSA) for both LH/RH sides of the lock. On the occasion where Fail Secure is selected the red and green wires on the LED cable will have to be swapped over to suit LH/RH sides of the lock.

FEL990 Series Monitoring Functions

Door Position Monitoring by Reed Switch

Lock Status Monitoring by a combination of 3 locking perimeters

- Locking Bar (Hub/Handle/s locked)
- Deadlatching Bolt (suppressed)
- Latchbolt (out)

Dual Key Override Monitoring (KOM)

Request to Exit (REX) via Hub/Handle(s)

LED Indication

LOCK INSTALLATION (swapping LED wires)

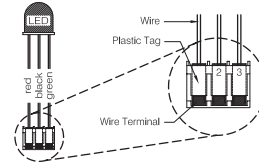

SWAPPING WIRES
Gently lift plastic tag holding terminal & slide wire terminal from plug. To insert wire terminal, slide back into plug.

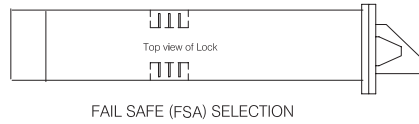

FAIL SAFE (FSA) SELECTION

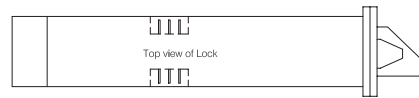

FAIL SECURE (FSE) SELECTION

FEL990M (12 Pin) Wire Connection Diagram

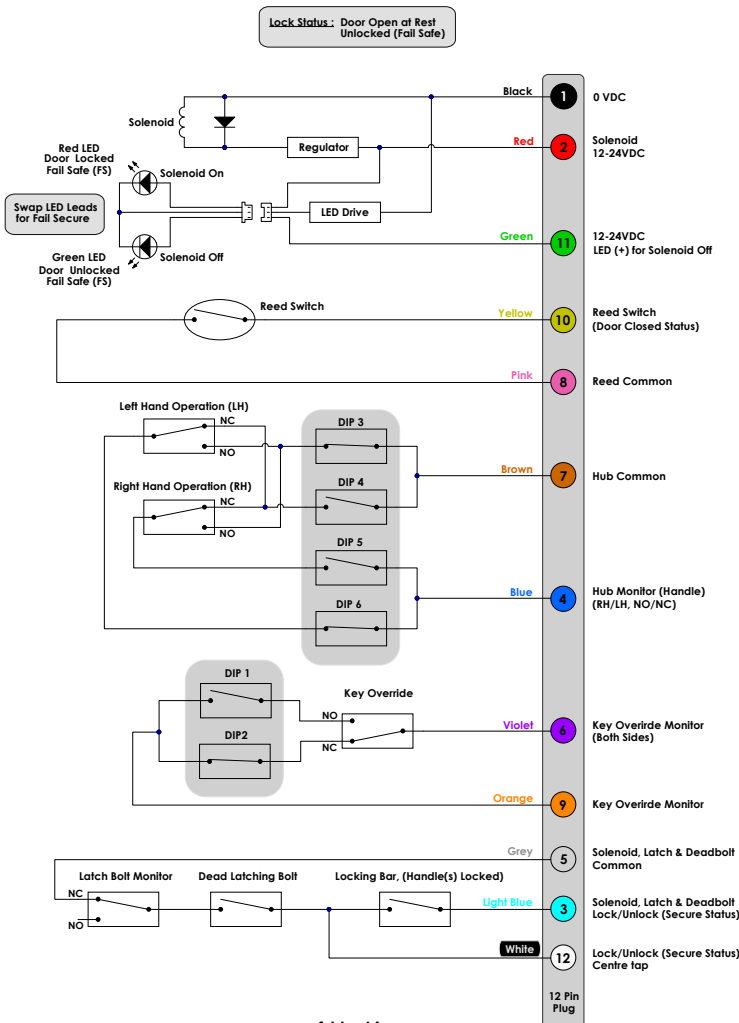

Electrical Specifications

Solenoid Activation

12-24V DC 350mA momentary, 100mA max operating Including LED if applicable

Lock Secure Status/Key Override Monitor

Microswitch max. rating 500mA @30V DC

Door Status Monitor

Magnetic Reed Switch 100mA operating

Plug arrangement

12 pin plug with 3m cable

Request to Exit (REX) Switches

Microswitches max. rating 1A @125VAC

PIN	Colour	Function
1	Black	0 VDC
2	Red	Solenoid black
3	Light Blue	Solenoid, latch and deadbolt lock/unlock
4	Blue	Hub monitor (handle) (RH/LH, NO/NC)
5	Grey	Solenoid, latch and deadbolt common
6	Violet	Key override monitor (both sides)
7	Brown	Hub common
8	Pink	Reed common
9	Orange	Key override monitor
10	Yellow	Reed switch (door closed status)
11	Green	LED (+) for solenoid off 12-24VDC
12	White	Lock/unlock (secure status) centre tap

DIP Switch Settings

HUBS*	Switch No.					
	1	2	3	4	5	6
LH NC	-	-	OFF	ON	OFF	ON
LH NO	-	-	ON	OFF	OFF	ON
RH NC	-	-	OFF	ON	ON	OFF
RH NO	-	-	ON	OFF	ON	OFF
KOM NC	OFF	OFF	-	-	-	-
KOM NO	-	-	-	-	-	-

*Hub monitoring is exit side only

This product is the subject of any one or more of the following patents, NZ2299577, AU717917, NZ529951, NZ535262, NZ534706, NZ534938, NZ537284, NZ534626.



ALLEGION

1800 098 094
info.au@allegion.com
fshlocking.com.au

©Allegion 2022