

# POWERSTACK™

## Technical Specifications

## Overview

PowerStack™ modular solar poles are a sustainable, cost effective way to power safety, security, and smart technologies for your business and community projects.

With totally off-grid vertical solar, you can power lighting, cameras, wireless sensors, and more without the time consuming utility approvals, digging and trenching required by AC power. The unique modular design means PowerStack can be installed almost anywhere and is optimised to capture maximum sunlight for each location.

Installed in under 30 minutes by a two person team, built to last in rugged environments, and delivering a minimum 5 day battery backup, PowerStack is solar, reimagined.

10

YEAR  
WARRANTY

↓ 30

MINUTES  
INSTALL TIME

5

DAYS BATTERY  
BACKUP

50-80%

OF PROJECT TIME  
SAVED

## Key features



T6 6000 series recycled aluminium extrusions



Anodised 2 step process



Glassless vertical solar panels



Locally manufactured



Wifi and Bluetooth enabled out of the box



Vandal resistant design



Concrete-free foundation for easy install



Customisable modular system designed for each location



Can withstand winds of up to 250km/hr, flood zone adaptive



Compatible with majority of technology providers in lighting, cameras, sensors



5 day battery backup and 10 year warranty

Solar Reimagined.

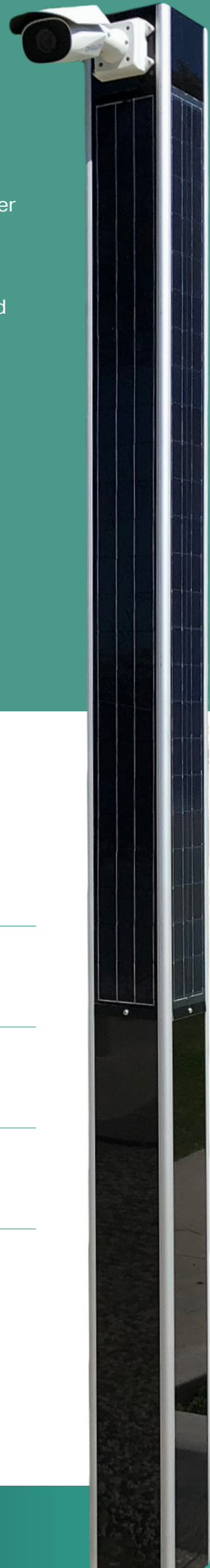

# Model range and ordering information

Pole section measurements provided in mm.

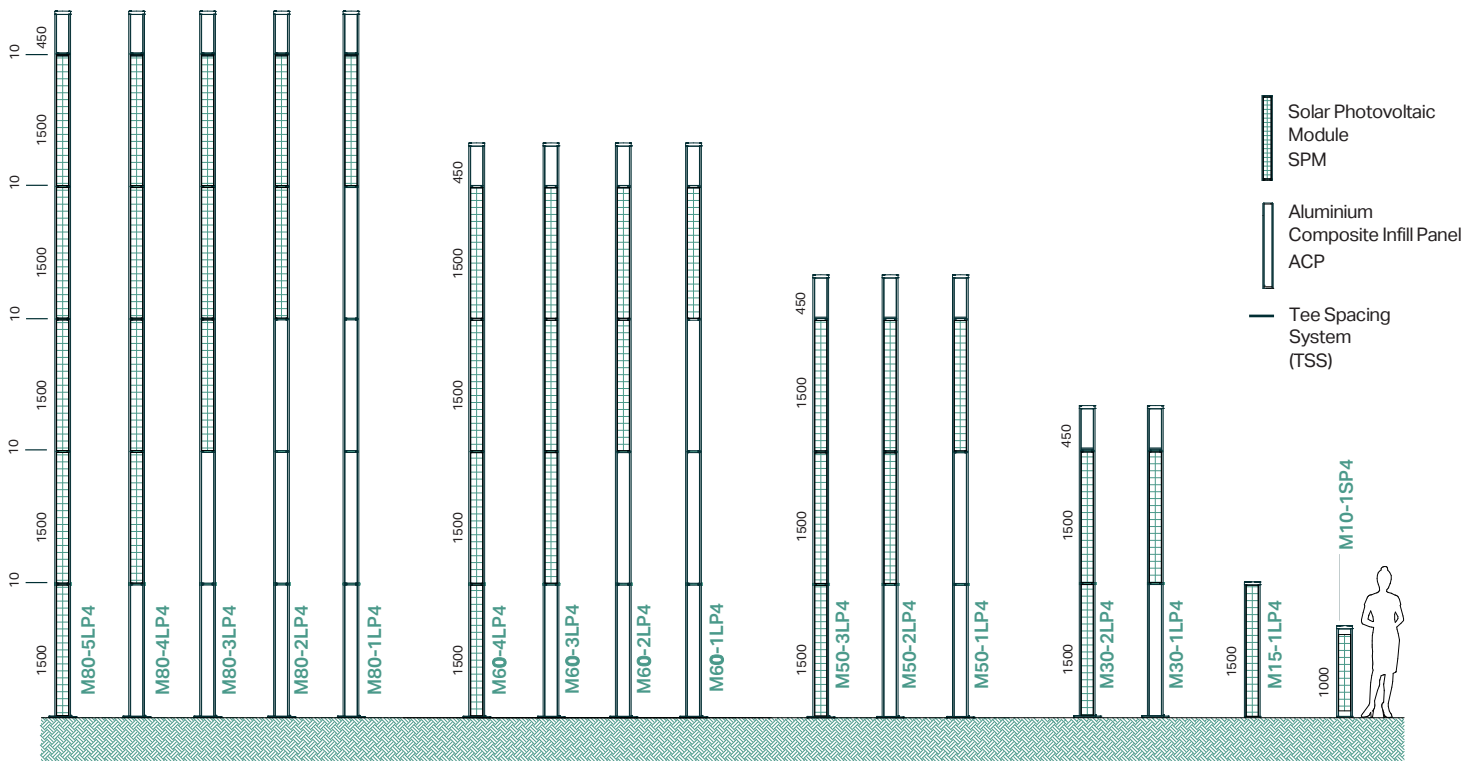

Pole Type	Solar Panels	Energy Storage	Operation profile
APS-M10	1SP4	Up to 3LFP	DN, FN, 9 HRS, 6 HRS, 3 HRS
APS-M15	1SP4 1LP4	Up to 5LFP	DN, FN, 9 HRS, 6 HRS, 3 HRS
APS-M30	1LP4 2LP4 3LP4	Up to 12LFP	DN, FN, 9 HRS, 6 HRS, 3 HRS
APS-M50	1LP4 2LP4 3LP4	Up to 20LFP	DN, FN, 9 HRS, 6 HRS, 3 HRS
APS-M60	1LP4 2LP4 3LP4 4LP4	Up to 25LFP	DN, FN, 9 HRS, 6 HRS, 3 HRS
APS-M80	1LP4 2LP4 3LP4 4LP4 5LP4	Up to 30LFP	DN, FN, 9 HRS, 6 HRS, 3 HRS

## Example model number:

APS-M50-3LP4-10LFP which refers to a 5.0m pole with 3 large solar panels on 4 sides and 10(LFP) batteries.

Number of solar panels on all systems are designed to the minimum sunlight hours for that region.

All systems have been sized for a back up of 5 days in winter sun conditions based on the load and panels selected.

Pole Height: All sizes in model no. are nominal sizes, see dimensions table for actual heights. Higher poles available upon request as a custom order.

Weight: Weights are indicative, showing unloaded pole without batteries and will vary based on system design.

Pole Type	L (mm)	W (mm)	H (mm)	Weight (kg)
APS-M10	175	175	1000	25
APS-M15	175	175	1500	40
APS-M30	175	175	3500	75
APS-M50	175	175	5000	90
APS-M60	175	175	6500	120
APS-M80	175	175	8000	140

# Zonal performance data

The wattage available from a PowerStack pole is determined by the location, power requirement of the technology payload, and run profiles. PowerStack systems are designed for the lowest annual sunlight hours for each zone, ensuring optimum performance year round.

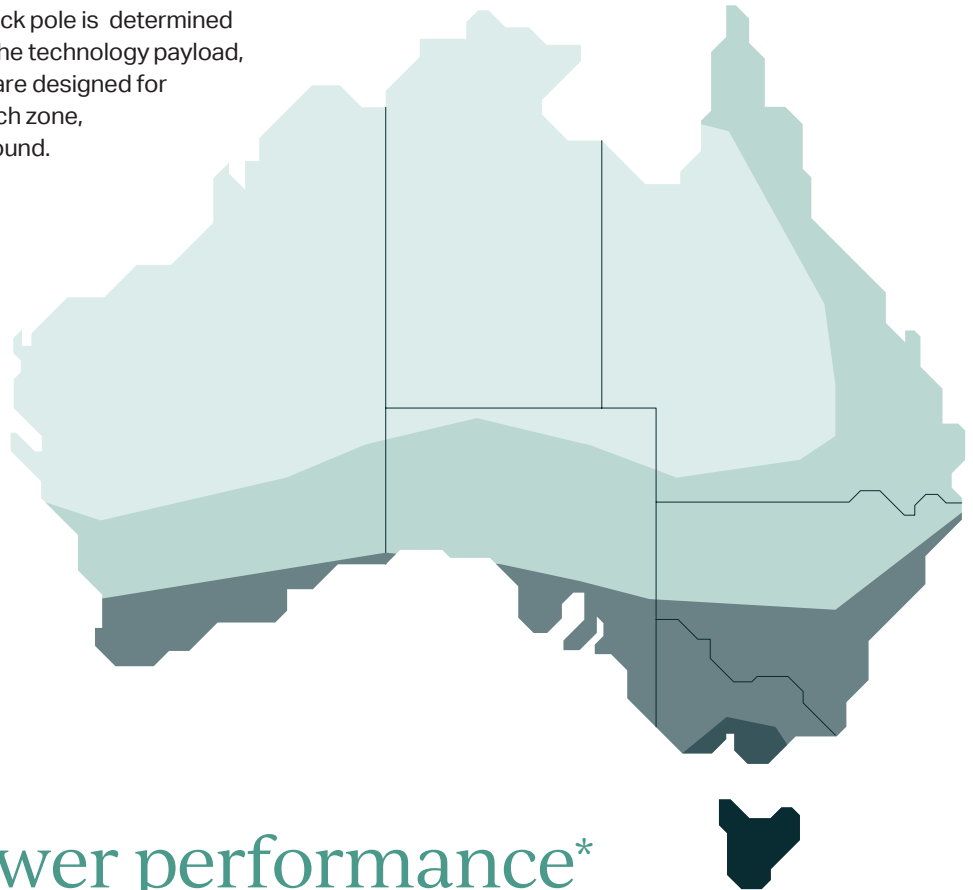

## Example power performance\*

\*All figures shown are indicative only, please contact your local PowerStack sales representative to your project requirements.

		Wattage				
	Pole Type	Zone 1	Zone 2	Zone 3	Zone 4	Zone 5
Half-night	APS-M10	8	11	15	19	23
	APS-M15	18	26	36	45	56
	APS-M30	37	53	75	91	113
	APS-M50	56	80	113	136	170
	APS-M60	75	107	151	184	227
	APS-M80	94	135	189	229	267
Full-night	APS-M10	3	4	6	8	10
	APS-M15	8	11	16	19	24
	APS-M30	16	23	32	39	48
	APS-M50	24	34	48	59	72
	APS-M60	32	46	64	78	97
	APS-M80	40	57	81	98	114
24/7 operation	APS-M10	1	2	3	4	5
	APS-M15	4	6	6	11	13
	APS-M30	8	13	18	22	28
	APS-M50	14	20	28	34	42
	APS-M60	18	26	37	45	56
	APS-M80	23	33	47	57	66

# Technical specifications

General		Energy Storage System	
Energy Source	Solar power	Technology	LiFePO <sub>4</sub> (Lithium Iron Phosphate)
Operating Temperature	-30°C to +60°C	Battery Management	Proprietary battery management system
Height	1m to 8m	Battery Backup	5 days minimum
Cross-sectional Dimensions	180mm x 180mm	Battery Cycle Life	>10,000 cycles
Warranty	10 years	Thermal	Insulation protection
System Design Life	>12 years	Connection	1.5mm copper strip
System Voltage	12/24V <sub>DC</sub> , 48V & PoE available	Replacement	>12 years
Wind Resistance	>250km/hr wind	Battery Capacity	3.5 times maximum load
Pole Material	T6 6000 series aluminium extrusions (60%+ recycled)	Battery Voltage	13.6 V <sub>DC</sub>

Design		Energy Distribution Centre	
Solar	1.2 x middle of winter irradiance	Material	Powder coated galvanised sheet metal
System Autonomy	5 days backup from solar and battery systems	Terminal	Wago 2002 series
Exterior	Shatterproof glassless solar modules	Isolation	Lever blade isolation
Structure	>250km/hr wind (Category C Cyclone)	Control System	Maximum power point tracking
Pole	Lightweight aluminium design	Voltage	12/24V Auto sense
Components	Internally mounted modular assembled design	Circuit Protection	Mini blade fuse

Solar Panel	
Technology	Monocrystalline cells
Encapsulant	Shatterproof glassless polymer
Life Expectancy	>15 Years
Solar Efficiency	17-19%
Connection	Waterproof 30A connection system
Voltage	28 V <sub>OC</sub>

Pole	
Material	T6 6000 series aluminium
Coating	2 step architectural anodise
Estimated Life	>30 Years
Process	Extruded
Base	Base hinge pole type
Foundation Bolts	20mm
Colour	Black or natural anodised



PowerStack reserves the right to make changes at any time in order to supply the best product possible. See also warranty and terms and conditions for further sale information.

# Mechanical drawings

All components of the PowerStack poles are inserted into the extrusion from the top, except for the Hinge Base System (HBS). Maintenance is performed by simply winching down the pole to the horizontal position and removing the Top Cap Device (TCD) to access the Energy Distribution Centre (EDC) and Energy Storage System (ESS).

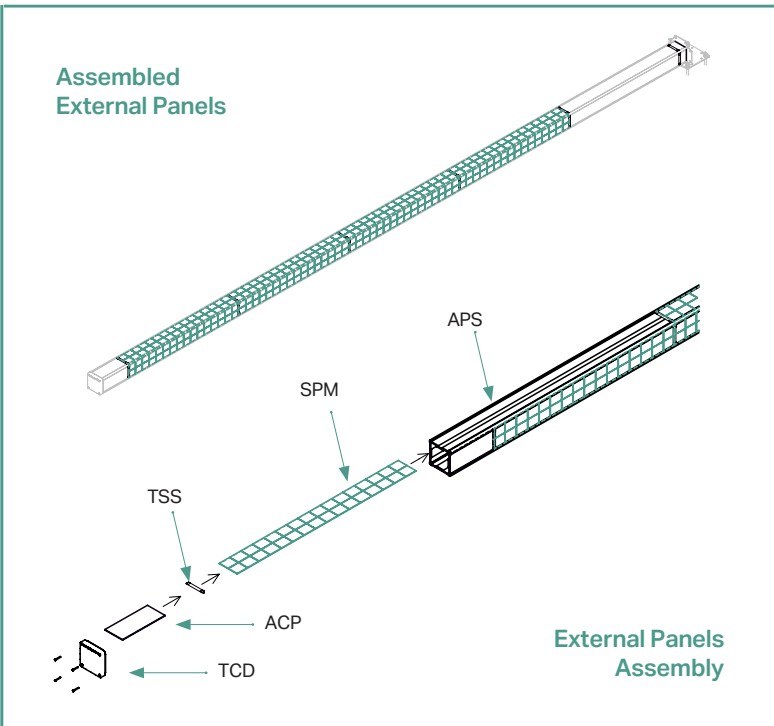
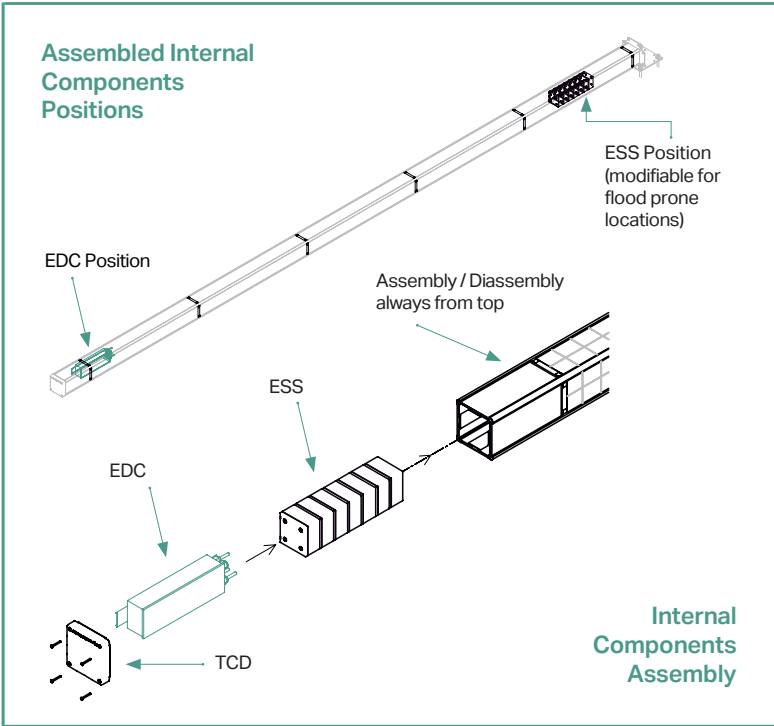

## Label Key

- APS - Aluminium Pole System
- SPM - Solar Photovoltaic Module
- ESS - Energy Storage System
- EDC - Energy Distribution Centre
- TSS - Tee Spacing System
- ACP - Aluminium Composite Panel
- CFF - Concrete-free Foundation (plate and micropiles)
- HSS - Hinge Sleeve System
- TCD - Top Cap Device
- HBS - Hinge Base System

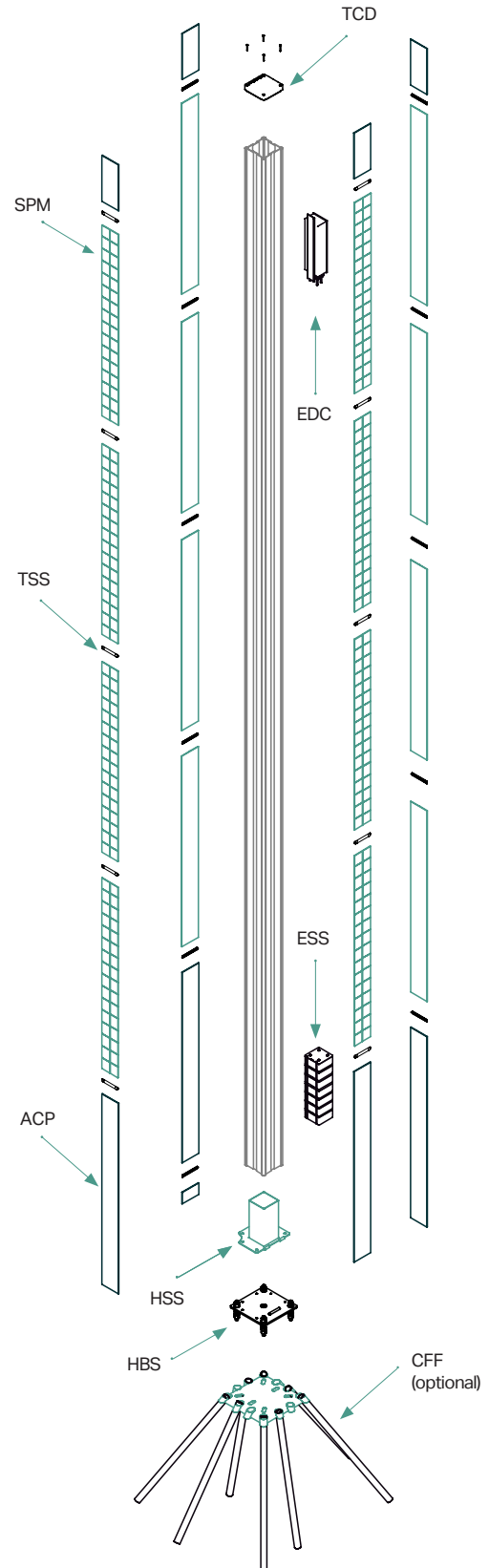



Post At Full Elevation

Post Winched Down For Maintenance

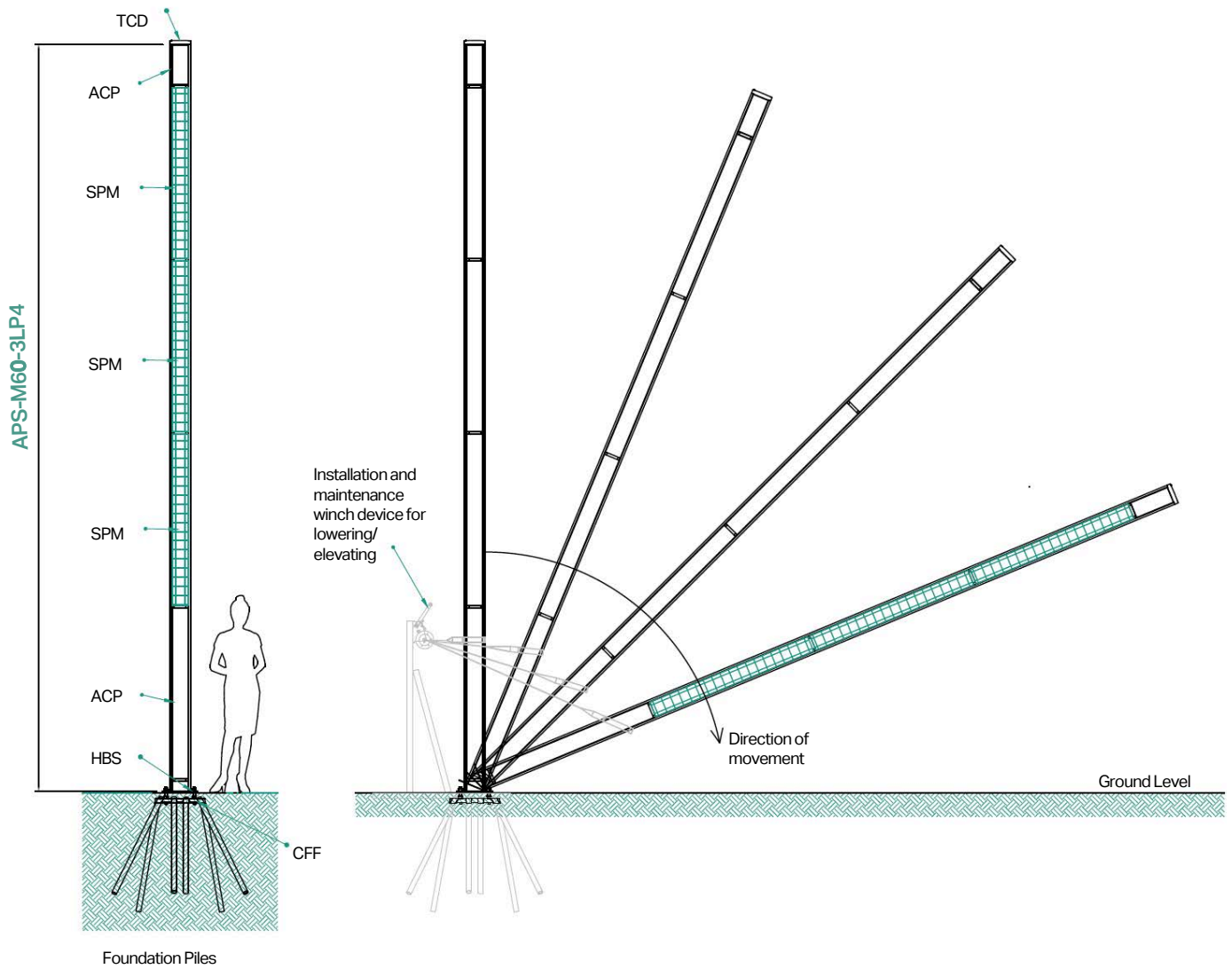

Hinge Sleeve, Base Plate And Micropile Detail

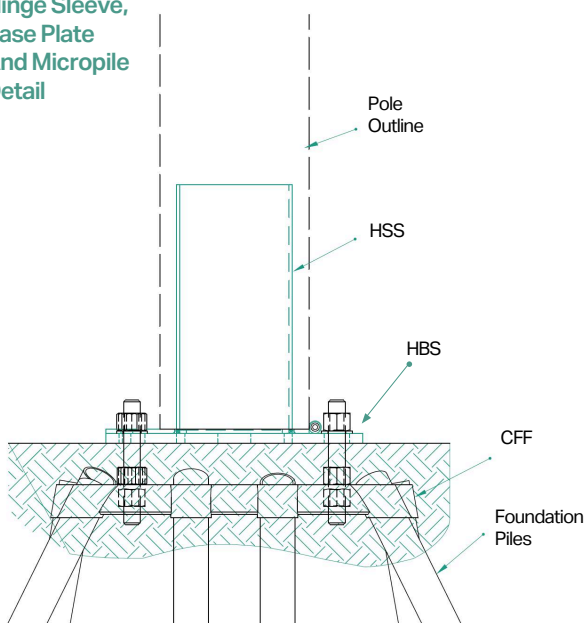

Stainless Steel Base System, Cross-sectional Diagram

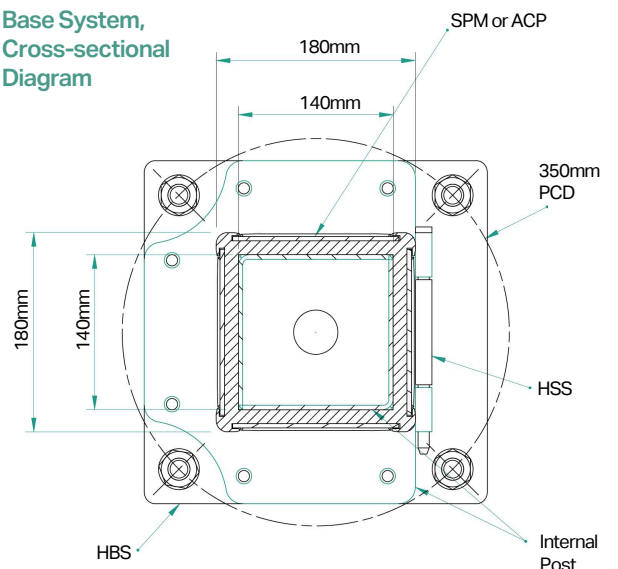

# Foundation options

Installation of the PowerStack poles is predominantly carried out utilizing the Concrete-free foundation (CFF) System. This system requires no digging and is installed by a two person team using hand operated tools. The number of micropiles required is determined by pole height, local wind category and geotechnical reporting, which covers all considerations and requirements within local structural standards.

Our CFF can be placed in cyclonic wind zones and in soft, sandy ground. PowerStack poles are also compatible with other foundation types, please speak to our team about your requirements.

Aerial view of CFF and detail showing micropiles

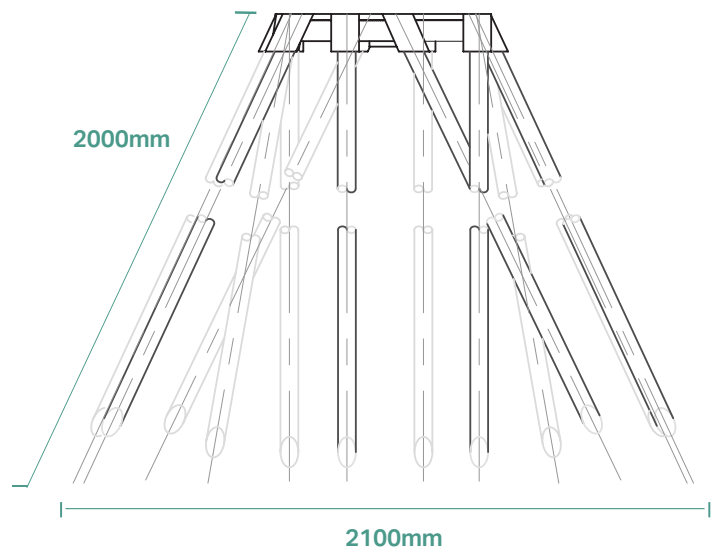
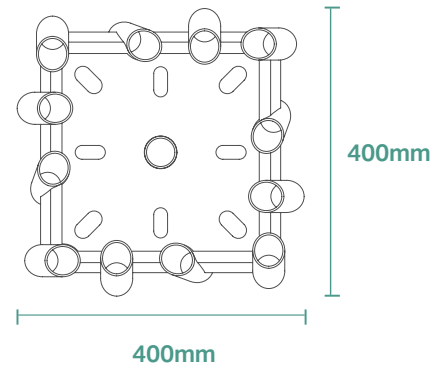

## Anchor Bolt Position Dimensions

Showing pitch circle diameter (PCD) for 400mm CFF plate. For use with M30 PowerStack Systems and above.

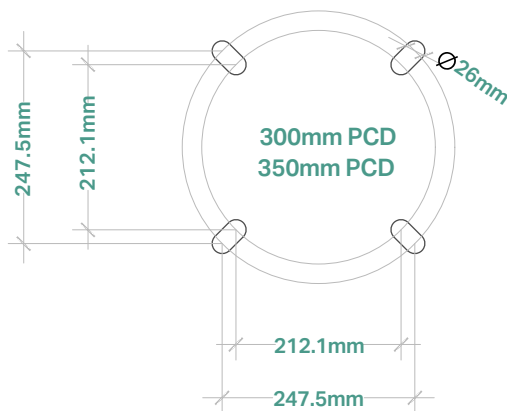

## CFF Design System\*

	APS-M30	APS-M50	APS-M60	APS-M80
Sand / Soft soil	400-6	400-8	400-8	400-12
Medium soil / Clay soil	400-4	400-6	400-6	400-8
Firm soil	400-4	400-6	400-6	400-6

### Example CFF design

APS-M60, 400-8 which refers to 6m PowerStack pole with 400mm square CFF plate using 8 of the 2m micropiles, ideal in sand or soft soil conditions.

\* Indicative calculations only, geotechnical report must be carried out to determine detailed soil conditions. CFF is available for the M10 and M15 PowerStack poles, please speak to our team.

## Alternative Foundations Designs

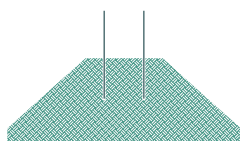

Above ground concrete foundation

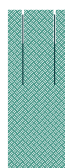

Pier concrete foundation

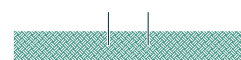

Pad concrete foundation

The above foundations are examples only and do not provide an exhaustive list. For further details and sourcing assistance for alternative foundation designs, please speak to our team about your requirements.

# POWERSTACK™

---

## Australian Office

165 Berkeley Road  
Berkeley NSW 2509  
Tel: 1300 049 505  
info.au@powerstack.energy

## American Office

4995 Bell Springs Road  
Factory #2  
Dripping Springs TX 78620  
Tel: +1 512 222 5550  
info.us@powerstack.energy

 **powerstack.energy**  
**info@powerstack.energy**

©2023 PowerStack™. All rights reserved.

©2023 PowerStack™ is a registered trademark of PowerStack and PowerStack Energy in all geographies in which the company operates. All other trademarks used are the property of their respective owners and PowerStack makes no claim to ownership. PowerStack reserves the right to introduce modifications to this document and the systems detailed therein without notice.